



Operation and Installation Manual

Pulsar® Precision 30 System

Model PS-1HCE30



Table of Contents

1	Safety Precautions	4
1.1	Safety Conventions	4
1.2	Safety Statements for the Pulsar® Precision 30 System	5
2	Introduction	7
2.1	Overview of Operation	7
2.2	Process Flow Diagram	8
3	Pulsar® Precision Feeder Overview	9
3.1	Components List	9
4	Pre-installation Instructions	10
4.1	Prepare the Site	10
4.1.1	Site Requirements (Standard Installation)	10
4.2	Gather Equipment for Feeder Installation	10
4.2.1	Pulsar® Precision 30 Components	10
4.2.2	Essential Equipment Supplied by Others	10
4.2.3	COTS Tools	11
4.2.4	PPE	11
4.3	Pre-Installation Checklist	11
5	Installation Instructions	12
5.1	Install the Venturi Bypass	12
5.2	Install the Flow Indicator and Solenoid Valve	13
5.3	Install the Discharge Assembly and Check Valve	13
5.4	Connect the Pulsar® Precision 30 to the Pool Recirculation System	13
6	Post-Installation Instructions	14
6.1	System Startup	14
6.1.1	Feeder Preparation	14
7	Operation Instructions	15
7.1	Feeder Operation	15
7.2	Venturi Suction Verification	15
8	Preventative Maintenance	16
8.1	Preventative Maintenance Schedule	16
8.1.1	Monthly Maintenance	16
8.1.2	Semiannual Maintenance	17
8.2	Cleaning Procedures	17
8.2.1	Equipment Needed	17
8.2.2	Chemical Free Cleaning	17
8.2.3	Chemical Cleaning	18
9	Troubleshooting Guide	19
10	Appendix	20
10.1	Requirements and Specifications	20
10.1.1	Requirements for Product Installation and Operation	20
10.1.2	Product Specifications	20
10.1.3	Flow Based Chlorine Output Rate	21
10.2	Replacement Parts List and Views	22
	Limited Warranty	26

List of Figures

Figure 1. Pulsar® Precision 30 Flow Based Installation	8
Figure 2. Pulsar® Precision 30 Chemical Controller Installation	8
Figure 3. Exploded view of Pulsar® Precision 30 Feeder	9
Figure 4. Feeder Major Components View	22
Figure 5. Feeder Inlet and Discharge Components View	23
Figure 6. Base Interior Components View	24
Figure 7. Exterior Components View	25

List of Tables

Table 1. Pre-installation Checklist	11
Table 2. Suction Flow Chart	12
Table 3. Post-Installation Checklist	14
Table 4. Site Requirements	16
Table 5. Monthly Maintenance	16
Table 7. Semiannual Maintenance	17
Table 8. Troubleshooting Guide	19
Table 9. Site Requirements	20
Table 10. Accessory Requirements	20
Table 11. Operational Specifications	20
Table 12. Chemical Feed Rate Specifications	21
Table 13. Chlorine Output Rate on Pools	21
Table 14. Chlorine Output Rate on Spas	21

1 Safety Precautions

⚠ Danger, ⚠ Warning, ⚠ Caution, and Note statements are used throughout this manual to emphasize important safety information. The statements are defined below.

1.1 Safety Conventions











 **Danger:** Indicates a hazardous situation which, if not avoided, will result in death or severe injury.

 **Warning:** Indicates a potentially hazardous situation which, if not avoided, can result in personal injury.

 **Caution:** Indicates a potentially hazardous situation which, if not avoided, can result in minor personal injury or equipment damage.

Note: Information that may assist in completing a task correctly or for maintaining the machine in good operating condition.

1.2 Safety Statements for the Pulsar® Precision 30 System

-
-  **Warning:** For your protection, carefully and completely read the information provided in this manual before attempting to assemble, install, operate, or maintain this product. Retain these instructions for future reference. Failure to follow the instructions or information in this manual may result in injury and damage to the product and may affect warranty coverage.
-
-  **Danger:** Fire or explosion could result from contamination or use of any other chlorinating compound!
-
-  **Danger:** Calcium hypochlorite is hazardous. Please refer to the Safety Data Sheet for additional information and precautions regarding the proper handling of Pulsar® Plus Briquettes. If any part of this profile is unclear to you, please stop immediately and contact Solenis at (800) 478-5727.
-
-  **Danger:** This system contains liquid under pressure and calcium hypochlorite solution can be discharged unexpectedly. Operate and service all components and attached piping that contain liquid cautiously until you are certain that the system has been depressurized and drained. Failure to do so may result in death or serious injury.
-
-  **Danger:** Use suitable personal protective equipment (PPE) at all times to avoid physical contact with calcium hypochlorite solution or vapor. Failure to do so may result in death or serious injury. Please refer to the Safety Data Sheet for additional information and precautions regarding the proper handling of calcium hypochlorite.
-
-  **Danger:** Do not allow Pulsar® Plus Briquettes to come into contact with any foreign matter or chemicals. Calcium hypochlorite is chemically reactive with many substances including, but not limited to water, water treatment products, pool treatment products, acids, organics, nitrogen-containing compounds, dry powder fire extinguishers (containing mono-ammonium phosphate), oxidizers, and corrosive, flammable, and combustible materials. Contamination or improper use of Pulsar® Plus Briquettes may cause a violent reaction that produces heat, an explosion, a fire, and the release of toxic gases, and result in death or serious injury. Please refer to the Safety Data Sheet for additional information and precautions regarding the proper handling of calcium hypochlorite.
-
-  **Danger:** All wiring connections, fusing, grounding, inspection, and maintenance of wiring must be performed by a licensed electrician in accordance with the National Electric Code (NEC), Occupational Safety and Health Act (OSHA) in the United States, and all local electrical codes. Failure to properly install and wire this product can result in property damage, serious injury, or death, and may affect warranty coverage.
-
-  **Warning:** Clean up, without delay, any leakage or spillage of Pulsar® Plus Briquettes or calcium hypochlorite solution. Please refer to the Safety Data Sheet for additional information and precautions regarding the proper disposal of calcium hypochlorite. Failure to do so may result in death or serious injury.
-
-  **Warning:** Always operate system with electrical component enclosures in place. Failure to do so may result in injury.
-
-  **Warning:** Always operate system components with safety guards in place. Failure to do so may result in injury.
-

 **Warning:** Observe and follow all location-specific safety procedures. Failure to do so may result in injury.

 **Warning:** Always be careful when adding muriatic acid to water; this combination creates an exothermic reaction, which gives off heat. Failure to take care may result in serious injury.

 **Caution:** Use only replacement parts identified in 10.2 Replacement Parts List and Views on page 22. Do not paint over or remove unit nameplates, labels, or tags so that proper replacement parts may be identified.
The system is designed with specific motor characteristics. Changing motor types will change the operating characteristics of the system, which may cause injury and may void the warranty of this chlorinator.

 **Caution:** Use of any briquettes or other chemicals other than the Pulsar® Plus Briquettes designed for use with this chlorinator is hazardous, possibly causing fire and/or explosion and will void this warranty.

2 Introduction

The patented Pulsar® Precision 30 feeder creates a consistent solution of calcium hypochlorite used for water disinfection.

2.1 Overview of Operation

The Pulsar® Precision 30 feeder operates as follows:

1. Pulsar® Plus Briquettes are placed in a basket and suspended over the solution reservoir.
2. The control box is plugged into a chemical controller output and powered on.
3. When the chemical controller requires chlorine, the feed solenoid valve opens allowing water from the pool return to enter the inlet water manifold at the proper supply flow rate.
4. Low-velocity, high-volume water enters the reservoir and covers the bottom of the basket.
5. Pulsar® Plus Briquettes erode into the reservoir and create a consistent 0.7% available chlorine solution with 84 °F [28.8 °C] inlet water temperature.
6. The chlorinated solution fills the reservoir, lifting the float switch connected to the discharge valve until the valve opens.
7. The discharge valve and outlet tubing are connected to a Venturi. The vacuum generated by the Venturi suction drains the reservoir tank and sends the concentrated solution into the pool return.

2.2 Process Flow Diagram

Figure 1. Pulsar® Precision 30 Flow Based Installation

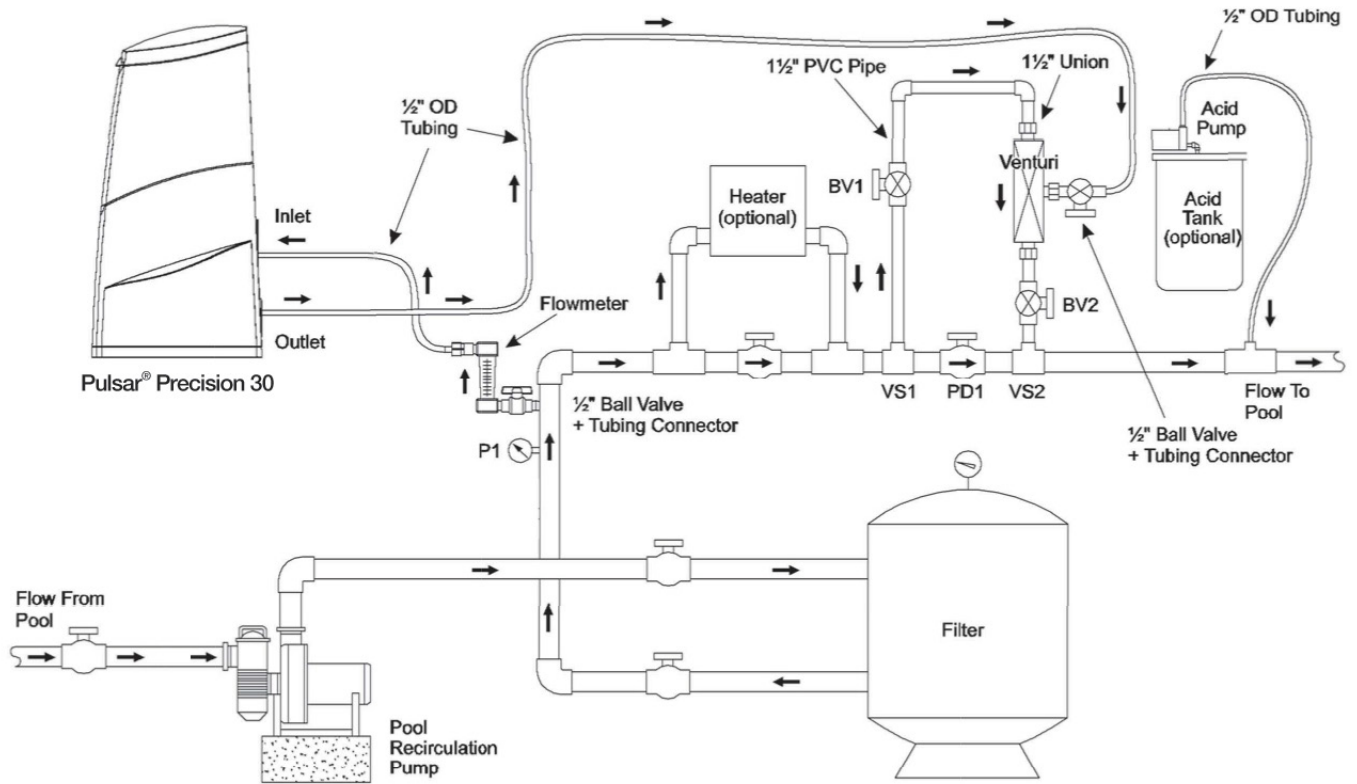
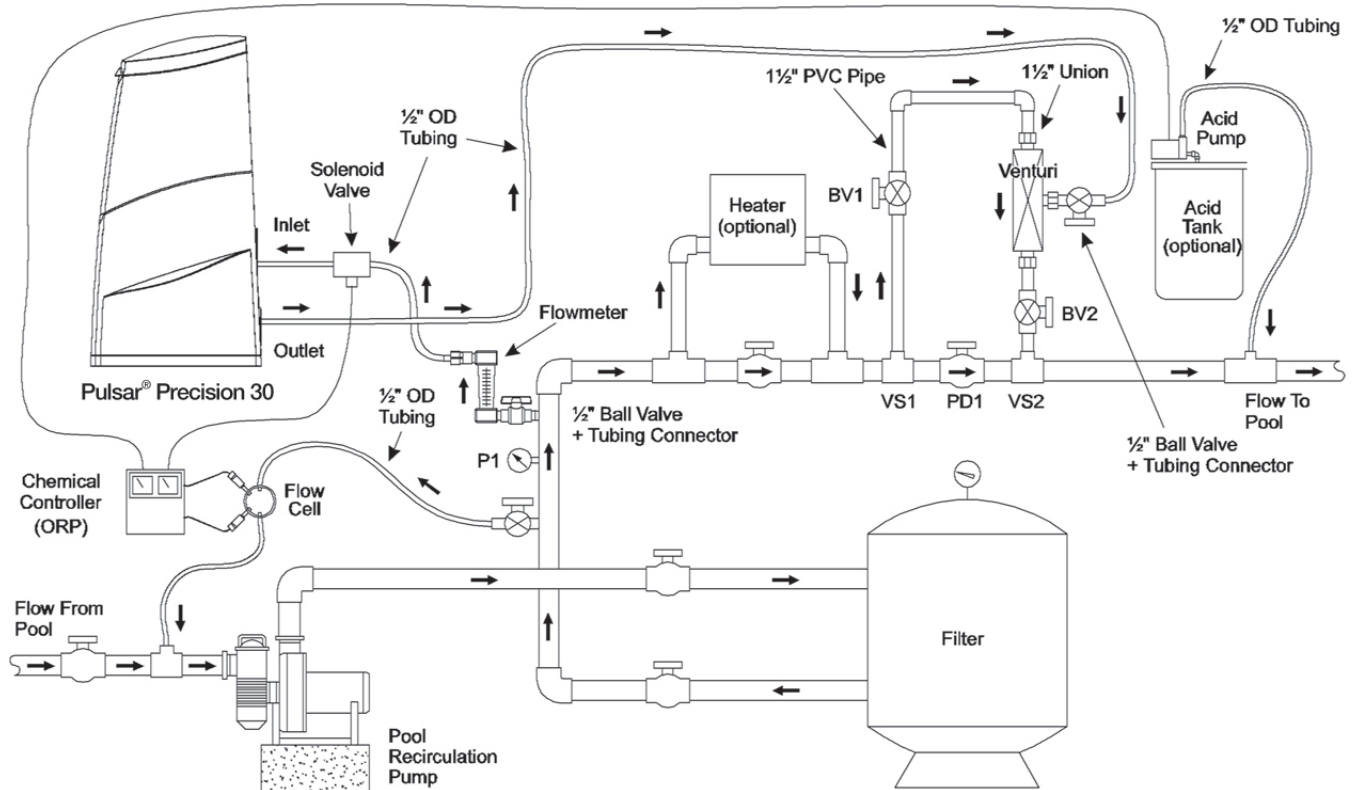

Figure 2. Pulsar® Precision 30 Chemical Controller Installation



3 Pulsar® Precision Feeder Overview

3.1 Components List

The Pulsar® Precision 30 Feeder includes these components:

- A. Hopper, which includes:
 - A1 Hopper lid, hinge pin, and retainer
 - A2 HCE 30 grid/with Diffuser
 - A3 HCE bowl
 - A4 HCE bowl frame w/rubber feet
- B. Base, which includes:
 - B1 Discharge valve assembly
- C. Installation parts, includes:
 - C1 Post filter installation kit (not shown)
 - C2 Optional solenoid valve and power supply (not shown)

Figure 3. Exploded view of Pulsar® Precision 30 Feeder

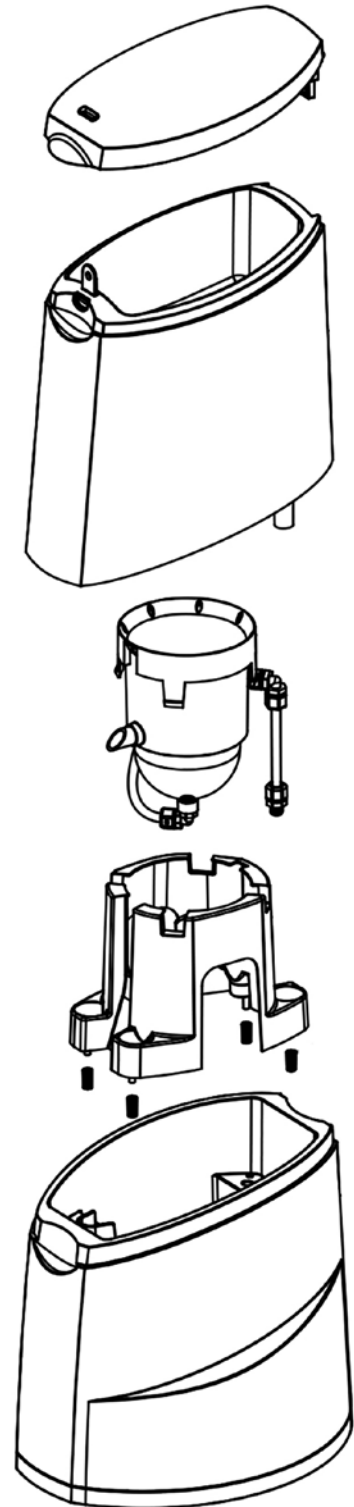

4 Pre-installation Instructions

4.1 Prepare the Site

Before installing equipment for Optional ORP Use, ensure that:

1. The site has all electrical connections installed. All electrical lines should be secured to meet site safety procedures and to prevent tripping over electrical lines.

 **Danger:** All wiring connections, fusing, grounding, inspection, and maintenance of wiring must be performed by a licensed electrician in accordance with the National Electric Code (NEC), Occupational Safety and Health Act (OSHA) in the United States, and all local electrical codes. Failure to properly install and wire this product can result in property damage, injury, or death, and may affect warranty coverage.

2. Site meets criteria noted in Site Requirements below.

4.1.1 Site Requirements (Standard Installation)

- The feeder must fit in the selected room with enough clearance for maneuvering and servicing the equipment.
 - Recommended clearance for feeder installation is 48" L x 48" W x 76" H [121.9 cm x 121.9 cm x 193.0 cm]
 - Minimum clearance for feeder installation is 36" L x 36" W x 64" H [91.4 cm x 91.4 cm x 162.6 cm].
- The room must have proper ventilation.
- The room must be climate-controlled between 40 °F – 90 °F [4 °C – 32 °C].
- Determine the location of the Venturi bypass.
 - The bypass loop should always be installed downstream of the filter and heater (if present)
 - Minimize the backpressure of the Venturi by eliminating or limiting the use of 90° elbows on the outlet side.
- Required electrical service (For optional ORP installation only) as follows:
 - Use with a solenoid valve requires a chemical controller 120 V chlorine demand output.
- The following cable lengths need to be considered for placement:
 - The solenoid valve DIN and power supply cable is 6 ft [1.8 m]
 - The single DIN extension cable is 9.8 ft [93 m]

4.2 Gather Equipment for Feeder Installation

Assemble these products in preparation for installation:

- Pulsar® Precision 30 components
- Essential equipment supplied by others
- Commercial off-the-shelf (COTS) tools
- Personal Protective Equipment (PPE)

4.2.1 Pulsar® Precision 30 Components

See the 3.1 Components List on page 9.

4.2.2 Essential Equipment Supplied by Others

- 1½" Sch 40 pipe
- Three (3) 1½" ball valves
- 1½" Sch 40 elbows, 45° and 90°

- ½" [1.27 cm] flexible tubing
- PVC primer and glue
- Saddle clamps for connection to 1½" PVC pipe from pool return (optional)
- Plumber's tape

4.2.3 COTS Tools

- Drill
- 1¾" hole saw and 1½" NPT tap (optional)
- Saddle clamps (optional)
- Pipe wrenches or gas pliers
- Tubing cutters
- Saw (to cut PVC pipe)

4.2.4 PPE

- Rubber gloves
- Safety glasses
- Apron

4.3 Pre-Installation Checklist

Table 1. Pre-installation Checklist

Item No	Check	Completed?
1	Is all PPE on Hand?	
2	Does the site meet all criteria noted in 4.1.1 Site Requirements (Standard Installation) on page 10?	
3	Have inlet and outlet locations on the pool return post filter been identified?	
4	Are all Pulsar® Precision components on hand?	
5	Is all essential equipment supplied by others on hand?	
6	Are all COTS tools and other equipment on hand?	
7	Optional ORP Installation - Is a licensed electrician available ?	

5 Installation Instructions

Note: The next steps involve creating a bypass loop on the pool return for installation of a Venturi. This loop can be created by drilling and tapping or splicing into the return line with tees. We refer to using the drill and tap method. You may find it preferable to splice in tees to make these connections. It will also be necessary to install a ball (or gate) valve in the return line at location "PD1" in Figure 1 and Figure 2 on page 8. This valve when partially closed, will force water to flow through the Venturi creating the suction needed to evacuate the feeder.

Note: Use the suction flow chart in Table 2 for properly setting the venturi bypass valve

Table 2. Suction Flow Chart

Inlet Pressure (psi)	Outlet Pressure (psi)	Flow Through Venturi (gpm)	Suction Flow (gpm)
5.5	5.0	23.0	1.0
6.0	5.0	28.0	1.6
6.5	6.0	24.0	1.0
7.5	6.0	28.0	1.5
7.5	7.0	26.0	1.0
8.0	7.0	28.0	1.6
12.0	10.0	32.0	1.0
12.5	10.0	34.0	1.3
15.5	12.0	37.0	1.0
17.5	15.0	38.0	1.0
18.0	15.0	39.0	1.3
21.5	17.0	41.0	1.0
22.0	17.0	42.0	1.3

5.1 Install the Venturi Bypass

Note: Refer to the schematics in Figure 1 and Figure 2 on page 8 and Figure 7 on page 25 for drilling, tapping, and part installation locations in the following steps.

1. Drill a 1 $\frac{3}{4}$ " hole at location "VS1" found on the schematic drawing.
2. Tap the 1 $\frac{3}{4}$ " hole with a 1 $\frac{1}{2}$ " NPT tap. Options for this step include the use of saddle clamps instead of drilling and tapping or splice in a tee with 1 $\frac{1}{2}$ " pipe size leading to Venturi System loop.
3. Drill a 1 $\frac{3}{4}$ " hole at "VS2".
4. Tap the 1 $\frac{3}{4}$ " hole with a 1 $\frac{1}{2}$ " NPT tap. Options for this step include the use of saddle clamps instead of drilling and tapping or splice in a tee with 1 $\frac{1}{2}$ " pipe size leading to Venturi System loop.

Note: Below grade systems will require the addition of ball valves at locations "BV1 & BV2" in Figure 1 and Figure 2. This will allow the Venturi System to be isolated for servicing.

5. Take one Union for the Venturi system apart. Note that they have different halves. Glue these two halves of the union onto the Venturi.
6. Take the other union apart and install on the Union halves on the Venturi (Figure 1, Figure 2, and Figure 7).

7. Apply Teflon tape to Tubing Connector (Figure 7 - Part 4C) and install on the ½" Ball Valve (Figure 7 - Part 4D).
8. Install ½" ball valve (Figure 7 - Part 4D) on ½" MNPT vacuum port of Venturi (Figure 7 - Part 4F).
9. Close the valve.
10. Complete installation of Venturi bypass loop using 1½" PVC pipe and fittings.

5.2 Install the Flow Indicator and Solenoid Valve

1. Turn off the pool recirculation pump.
2. Close valves between the pool filter system and the pool.

Note: The flow indicator should be mounted vertically. The use of flexible tubing may be required for proper orientation of the flow indicator.

3. Drill an ⅜" hole after the filter (before heater if present) where "P1" is on Schematic Figures 1 or 2. Tap the ⅜" hole with a ½" NPT tap.
4. Install close nipple in ½" ball valve. Apply plumber's tape to all threads.
5. If using with a chemical controller, install the solenoid valve on the outlet of the flow indicator
6. Mount the solenoid valve on a platform so that stress on the inlet tubing and flow indicator is limited
7. Install tubing connector on the outlet (top) port of the flow indicator
8. Install ball valve into the drilled and tapped hole in step 3.
9. Install the flow indicator on to the ball valve.
10. Close the ball valve installed in Step 4.

5.3 Install the Discharge Assembly and Check Valve

1. Install the 45° elbow, threaded nipple, ball check valve, and 90° tubing connector on the ½" threads protruding from the bottom of the base of the feeder.

5.4 Connect the Pulsar® Precision 30 to the Pool Recirculation System

1. Place the Pulsar® Precision 30 Feeder in the pump room following the recommendations in Section 4 on page 10.
2. Install the tubing connector on the inlet to the feeder.
3. Install one end the ½" OD polyethylene tubing into the inlet tubing connector on the feeder.
4. Run the polyethylene tubing to the tubing connector installed on the flow indicator (upper position), cut to desired length and install.
5. Take more ½" OD polyethylene tubing and install one end to the discharge check valve assembly tubing connector.
6. Run the polyethylene tubing to the tubing connector on the Venturi suction, cut to desired length and install.

6 Post-Installation Instructions

Before first-time startup of the feeder, check:

Table 3. Post-Installation Checklist

Item No	Check	Completed?
1.	Is the Venturi bypass installed in accordance with the Figure 1 installation schematic	
2.	Is there any residual debris (plastic shavings, screws, and so on) inside the solution tank?	
3.	Are all tubing, fittings and valves to and from the feeder installed in accordance to section 5?	
4.	Are all fittings and unions tightened to prevent leaks?	
5.	Are flow directional arrows pointed in the correct direction of flow on the Venturi, solenoid valve, and check valves?	
6.	Is the grid placed in HCE bowl in the correct position	
7.	Is solenoid valve power supply plugged into the chemical controller chlorine output? (If applicable)	

6.1 System Startup

Note: Before starting up the equipment, ensure that the Post-Installation checklist has been completed.

6.1.1 Feeder Preparation

After completing the post-installation checklist:

1. Put on the appropriate PPE: long sleeved clothing, rubber gloves, apron, dust mask, and safety glasses.

 **Danger:** Use suitable personal protective equipment (PPE) at all times to avoid physical contact with calcium hypochlorite liquid or vapor. Failure to do so may result in death or serious injury. Please refer to the Safety Data Sheet for additional information and precautions regarding the proper handling of calcium hypochlorite.

 **Danger:** Fire or explosion could result from contamination or use of any other chlorinating compound!

 **Caution:** Use of any briquettes or other chemicals other than the Pulsar® Plus Briquettes designed for use with this chlorinator is hazardous, possibly causing fire and/or explosion and will void this warranty.

2. Open the hopper lid.
3. If not already installed, place grid into the hopper. Confirm that only one grid is installed in the hopper and placed in the correct orientation where the basket spout is on the bowl outlet. (Basket should not be able to rotate when placed correctly).
4. Use a scoop to fill the hopper with Pulsar® Plus Briquettes.

 **Caution:** Do not dump Pulsar® Plus Briquettes into the basket. Dumping will cause dust from calcium hypochlorite and can damage basket from force of load.

5. Close the hopper lid.
6. If using with a chemical controller, plug the solenoid valve power supply to the chlorine demand output of the chemical controller.

7 Operation Instructions

Note: Before starting up the equipment, ensure that the Post-Installation checklist has been completed.

7.1 Feeder Operation

To operate the Pulsar® Precision 30 Feeder:

1. Put on the appropriate PPE: long sleeved clothing, rubber gloves, apron, dust mask, and safety glasses.

 **Danger:** Use suitable personal protective equipment (PPE) at all times to avoid physical contact with calcium hypochlorite liquid or vapor. Failure to do so may result in death or serious injury. Please refer to the Safety Data Sheet for additional information and precautions regarding the proper handling of calcium hypochlorite.

2. Ensure that the inlet and outlet ball valves on the feeder and Venturi suction lines are closed.
3. Open the hopper lid and ensure that the hopper is filled with Pulsar® Plus Briquettes. Close the lid.
4. Partially shut the 1-½" Venturi bypass valve to create the pressure differential and create suction on the Venturi as shown in Table 2.
5. Fully open the feeder outlet ½" ball valve on the Venturi suction.
6. Slowly open the feeder inlet ½" ball valve until the flow meter reads 1.25 gpm max.
7. If on a chemical controller, once a chlorine signal is sent, the solenoid valve will open and allow water to flow into the feeder dissolving the briquettes. The valve will remain open for the duration of the chlorine signal.
8. During the feed cycle, ensure the inlet flow does not increase above 1.25 gpm as indicated on the flow meter. Inlet flow above this flow rate may result in an over flow condition.
 - The ESV (Emergency Shutoff Valve) provides a mechanical stop to prevent water from continuing to enter the feeder in an overflow.

7.2 Venturi Suction Verification

Note: A timer is needed to complete the following steps.

To ensure there is sufficient suction from the Venturi, a suction flow test must be performed.

1. Ensure there is flow to the feeder and take note of the flow rate on the flow meter.
2. Shut the ½" ball valve on the suction discharge tubing.
3. Open the ½" ball valve on the feeder inlet and allow water to fully enter the feeder. (If there is a solenoid valve installed, manually energize it so it allows water to flow into the feeder).
4. Allow water to flow into the feeder until the ESV automatically shuts down the flow, then shut the inlet ½" valve.
5. With your timer in hand, open the ½" valve on the feeder outlet/discharge tubing, start the timer and watch as the water is evacuated out of the tank until it is stopped by the discharge valve.
6. Watch the water level go down until the suction is stopped by the discharge valve.
7. Stop the timer and take note of the time.
8. Calculate the flow rate using the formula (1.5 Gallons / time in seconds) x 60 = flow rate (gpm) or (5.5 Liters / time in seconds) x 60 = flow rate (lpm).
9. If the calculated flow rate is equal to or below the inlet flow rate as shown on the flow meter, further close the Venturi bypass valve handle to increase the Venturi suction rate.
10. Repeat this test until the calculated flow rate is above the inlet flow rate.

Note: The bypass valve does not need to be fully shut to achieve the needed pressure differential.

8 Preventative Maintenance

8.1 Preventative Maintenance Schedule

Routine maintenance of the Pulsar® Precision 30 Feeder is minimized when proper pool water balance is maintained. Maintain pool water chemistry as follows:

Table 4. Site Requirements

Total Alkalinity	60 – 80 ppm
Calcium Hardness	200 – 1800 ppm
pH	7.2 – 7.6
LSI	-0.3 – +0.5

Note: Adherence to these recommendations will ensure the most effective and economical performance of the feeder.

Note: The use of Carbon Dioxide gas (CO₂) to lower pH will raise the Total Alkalinity significantly. High total alkalinity (over 80 ppm) will increase scale and solids buildup in feeder.

8.1.1 Monthly Maintenance

Complete each of the following tasks during the first week of each month.

Table 5. Monthly Maintenance

Action Needed	Maintenance Process	Time to Complete
Change/clean basket	See Clean the Grid (Online Cleaning Instructions) in Section 8.2	
Inspect inlet and outlet plumbing fittings	Verify that there are no leaks at any of the inlet and outlet ½" feeder fittings and 1½" Venturi piping and fittings and valves. 1. Close all isolation ball valves and re-plumb / replace any leaking piping and fittings.	2 min
Inspect inlet line strainer assembly (Optional for ORP use only)	1. With pressure in the line, visually inspect the strainer basket for leaks. Replace the entire basket assembly if leaking. 2. Close inlet ball valve. 3. Remove strainer basket and visually inspect for cracks and debris. 4. Remove strainer screen and wash it out prior to replacing it back into the basket. 5. If screen appears damaged or has a hole in it, replace with a new screen. 6. Re-install the strainer basket back into the strainer body.	10 – 15 min
Inspect discharge check valve	1. Close the outlet ball valve. 2. Unscrew the check valve unions to remove the check valve body. 3. Disassemble the check valve and inspect for calcium buildup and debris. Clean if necessary. 4. Visually check the seal for corrosion. If the seal is corroded, replace the check valve. 5. Re-assemble the check valve body ensuring to put the seal on the side of the ball. 6. Replace the check valve body back onto the unions, ensure arrow points away from feeder.	10 min
Inspect reservoir tank	▪ During feed cycle, if the solenoid valve is hot to the touch, consider replacing the valve. If the solenoid makes a rattling noise when energized, consider replacing the valve.	5 min

8.1.2 Semiannual Maintenance

Complete the following task during the first week of January and the first week of July.

Note: Maintenance that prevents the discharge line from clogging is critical to feeder operation.

Table 7. Semiannual Maintenance

Action Needed	Maintenance Process	Time to Complete
Inspect Venturi	<ol style="list-style-type: none">1. Close the inlet and outlet 1½" ball valves around the Venturi.2. Close the inlet and outlet ½" ball valves to the feeder.3. Disconnect the feeder discharge tubing from the Venturi.4. Remove the Venturi via the 1½" unions and visually inspect and verify it is not clogged with scale build up.5. If scale buildup is found, refer to cleaning instructions in Section 8.2	2 – 5 min
Optional with ORP use only. Inspect the solenoid valve	During feed cycle, if the solenoid valve is hot to the touch, consider replacing the valve. If the solenoid makes a rattling noise when energized, consider replacing the valve.	2 min

8.2 Cleaning Procedures

8.2.1 Equipment Needed

- PPE
 - Rubber gloves
 - Apron
 - Safety glasses
 - Long sleeved clothing
- Spare grid
- Pulsar® Acid Cleaner 50 or muriatic acid
- Water Hose

8.2.2 Chemical Free Cleaning

 **Danger:** Always use suitable personal protective equipment (PPE) to avoid physical contact with calcium hypochlorite liquid or vapor. Failure to do so may result in death or serious injury. Please refer to the Safety Data Sheet for additional information and precautions regarding the proper handling of calcium hypochlorite. Chemical Safety Data Sheets can be requested from your dealer / distributor.

Perform this chemical free cleaning procedure on a regular basis to prevent an unscheduled failure due to excessive scaling and solids buildup disrupting chlorine output. The frequency of cleaning will be different for every feeder due to a wide variety of variables including water quality, pump room environment, and usage.

1. Put on the appropriate PPE: long sleeved clothing, rubber gloves, apron, and safety glasses.
2. If possible, allow the hopper to run completely out of Pulsar® Plus Briquettes. If time does not allow full consumption of the briquettes, use a scooper to remove any remaining briquettes from the hopper and bowl.

 **Danger:** Do not use a scoop that was used for any other chemical other than calcium hypochlorite. Any trace or residue of other chemicals, even if not visible, can cause a dangerous chemical reaction that may result in serious injury and damage to equipment.

3. Shut the ½" ball valve on the feeder inlet.
4. Open the hopper lid.
5. Spray the hopper with water from the hose. Be sure to rinse off all solid residue from the grid and inside the HCE bowl. All solids and debris should flow down to the feeder base and get sucked out through the discharge valve. If the base starts overflowing, pause spraying until the Venturi catches up. Repeat the spray and pause pattern until the grid and bowl are free of solids, scaling, or debris.
6. Remove the grid from the hopper if closer inspection of the grid and bowl is needed to ensure all solids and debris have rinsed off from the bowl.
7. Once the hopper is clean, remove it from the base and set it aside.
8. Lift the hopper frame from the base and disconnect the tubing from underneath the bowl to completely free it from the base.
 - a. Inspect the base for solids and debris. Spray inside the base until all debris is removed through the discharge valve. Pause spraying intermittently to prevent overflowing the base.
9. Once the base is clean, reinstall the tubing to the tubing connector on the HCE bowl, and replace the hopper frame and hopper back onto the base. Use the figures in 10.2 Replacement Parts List and Views on page 22 to ensure all parts are replaced properly.
10. Open the inlet ½" ball valve when completed.

8.2.3 Chemical Cleaning

 **Danger:** Always use suitable personal protective equipment (PPE) to avoid physical contact with calcium hypochlorite liquid or vapor. Failure to do so may result in death or serious injury. Please refer to the Safety Data Sheet for additional information and precautions regarding the proper handling of calcium hypochlorite. Chemical Safety Data Sheets can be requested from your dealer / distributor.

 **Warning:** Always be careful when adding muriatic acid or Pulsar® Acid Cleaner 50 to water; this combination creates an exothermic reaction, which gives off heat. Failure to take care may result in serious injury.

The chemical free cleaning procedure of Section 8.2.2 is recommended as a regular preventative maintenance measure. If additional or more rigorous cleaning is required, use the chemical cleaning procedure in this section.

1. Follow steps 1 – 8 of the previous chemical free cleaning, Section 8.2.2.
2. Shut the ½" ball valve on the discharge valve assembly to isolate it from the Venturi suction.
3. Use the hose and spray water into the base until it is approximately 75% full. With the discharge ball valve completely shut, water should remain inside the bowl.
4. Start with adding approximately 2 oz of muriatic acid or Pulsar® Acid Cleaner 50 to the water in the base to create an acid solution. If there is some carbonate scale or solids in the base, you should start to immediately see some "fizzing" occur as the low pH solution dissolves the scale. Add more acid to the mixture if additional dissolving is needed.
5. If there was scaling on the grid and it was not able to be completely cleaned simply using water in steps 1 – 8, add the grid to the acid solution in the base for additional cleaning.
6. Let the base with acid solution sit for at least 30 minutes and inspect.
7. Once the base is fully cleaned of scale and solids, remove the grid or any parts thrown into the base, open the ½" ball valve on the discharge valve assembly and allow the Venturi to complete evacuate the acid solution from the base. This allows the acid solution to flow through and clean the discharge valve, check valve, tubing, and Venturi suction.
8. Reinstall the tubing to the tubing connector on the HCE bowl, and replace the hopper frame and hopper back onto the base. Use the figures in appendix section 10.3 to ensure all parts are replaced properly.
9. Open the inlet ½" ball valve when completed.

9 Troubleshooting Guide

Table 8. Troubleshooting Guide

Symptom	Probable Cause	Solution
No/low inlet water flow	Optional solenoid valve does not properly open	Replace solenoid valve. Check with dealer.
	½" Inlet ball valve closed	Open the inlet ball valve.
	Inlet strainer plugged	Clean inlet strainer.
	Emergency Shut Off Valve in Closed position.	If ESV is stuck, lower gently to reset.
	Optional solenoid power supply not connected	Check power supply is plugged into the chlorine signal output of the chemical controller
Insufficient chlorine	Feeder empty	Refill hopper with Pulsar® Plus Briquettes.
	No/low inlet water flow	See No/low inlet water flow section above.
	Clogged discharge line	Clean or replace discharge tubing and fittings. Refer to cleaning instructions, page 17.
	Clogged check valve	Remove and clean the check valve.
	Clogged Venturi	Remove Venturi and clean. Refer to cleaning instructions, page 17.
	Optional chemical controller signal not present	Ensure solenoid power supply is properly plugged into the chemical controller chlorine output. Refer to controller manual for troubleshooting.
Excessive chlorine	Optional chemical controller problem	Refer to the chemical controller anual.
	Clogged grid	Clean grid. Refer to cleaning instructions, page 17.
	Clogged HCE bowl outlet	Break off excess scale and refer to cleaning instructions, page 17.
Feeder overflow	Clogged discharge line	Clean or replace discharge tubing and fittings. Refer to cleaning instructions, page 17.
	Clogged Venturi	Clean Venturi. Refer to cleaning instructions, page 17
	Insufficient outlet suction	Excessive pressure drop on the Venturi outlet. Check with dealer.
	ESV Failure	Replace ESV. Check with dealer.
	Inlet flow rate too high	Check inlet flow meter and set to 1.25 gpm max.

10 Appendix

10.1 Requirements and Specifications

10.1.1 Requirements for Product Installation and Operation

Table 9. Site Requirements

Recommended Clearance	Feeder: 44" L x 30" W x 54" H [112cm x 76cm x 137cm]
Minimum Clearance	Feeder: 19.5" D x 15.5" W x 34" H [50cm x 39cm x 86cm]
Electrical	120 V AC power supply for chemical controller (Optional)

Table 10. Accessory Requirements

Chemical	Pulsar® Plus Briquettes
Discharge Tubing	½" [1.27 cm] OD Polyethylene flexible tubing
Water Inlet Tubing	½" [1.27 cm] OD Polyethylene flexible tubing

10.1.2 Product Specifications

Table 11. Operational Specifications

Dry Chemical Capacity	30 lbs [13.6 kg] of available chlorine)
Tank Size (Solution Volume)	1.5 gal [5.7 L]
Available Working Solution	0.5 gal [1.9 L]
Water Inlet Size	½" [1.3 cm] OD
Solution Outlet	½" [1.3 cm] OD
Shipping Weight	Approximately 20lbs [9 kg]
Operating Weight	Approximately 50lbs [23 kg]
Operating Temperature	40 °F – 95 °F [4.4 °C – 40.6 °C]
Feeder Dimensions	19.5" D x 15.5" W x 34.0" H [50cm x 39cm x 86cm]
Power Supply DIN Cable	6' [1.8 m] (Optional: For ORP use Only)
DIN Extension Cable	9.8' [3 m] (Optional: For ORP use Only)

Table 12. Chemical Feed Rate Specifications

Chlorine Delivery Rate (Pools)	2 – 36 lbs [0.9 kg – 16.3 kg] AvCl/day Maximum of 1.5 lbs [0.68 kg] AvCl/hr
Chlorine Delivery Rate (Spas)	2.5 – 42 lbs [1.13 kg – 19.05 kg] AvCl/day Maximum of 1.75 lbs [0.79 kg] AvCl/hr
Solution Strength	0.6 – 0.8% at 84 °F [28.8 °C] inlet water temperature
Water Inlet	1.25 gpm [4.7 lpm] @ 5 psi [0.34 bar] filter pressure
Venturi Discharge Rate	1.4 gpm [5.3 lpm] @ 3 psi [0.21 bar] differential on Venturi
Recommended Pool Size (For guidance only, see notes)	<ul style="list-style-type: none"> • Outdoor Non-Stabilized: Up to 50,000 gal. • Outdoor Stabilized: Up to 100,000 gal. • Indoor: Up to 150,000 gal. • Spas: Up to 10,000 gal.

Note: Above guidance is based on nominal bather loads with well-kept pool conditions. Heavy bather loads, pool leakage, frequent backwashing, use of other sanitization equipment, etc will change feeder sizing requirements.

Note: Higher flow rates (increased turn over rate requirement) mostly impact feeder sizing on very shallow water such as water slides or kiddie pools since these are less likely to maintain chlorine residuals regardless of bather load. These water features may require more feeder output and/or a bigger feeder model.

Note: Historical chlorine consumption data (how much chlorine the pool typically used per day/week/month) can help with feeder sizing requirements.

10.1.3 Flow Based Chlorine Output Rate

Inlet flow (gpm) vs Available Chlorine Delivery Rate (lbs/day)

Table 13. Chlorine Output Rate on Pools

Flow Rate (gpm)	AvCl (lbs/day)	Output %
0.3	2	25 %
0.6	18	50 %
0.9	26	75 %
1.25	36	100 %

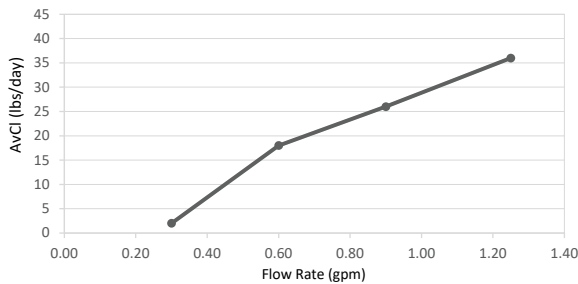
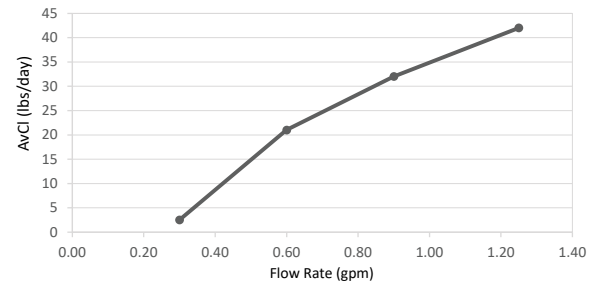

Table 14. Chlorine Output Rate on Spas

Flow Rate (gpm)	AvCl (lbs/day)	Output %
0.3	2.5	25 %
0.6	21	50 %
0.9	32	75 %
1.25	42	100 %



10.2 Replacement Parts List and Views

Part	Description	Part No.
1	FEEDER EXTERIOR COMPONENTS	
1A	Pulsar® Precision 30 Feeder	73379
1B	Pulsar® Precision 30 Hopper	251585
1C	HCE Bowl	233308
1D	HCE 30 Frame	251586
1E	Pulsar® Precision Base	251573
1F	Pulsar® Precision Lid	251578
1G	Pulsar® Hinge Pin	251570
1H	Pulsar® Lid Hinge	251575

Figure 4. Feeder Major Components View

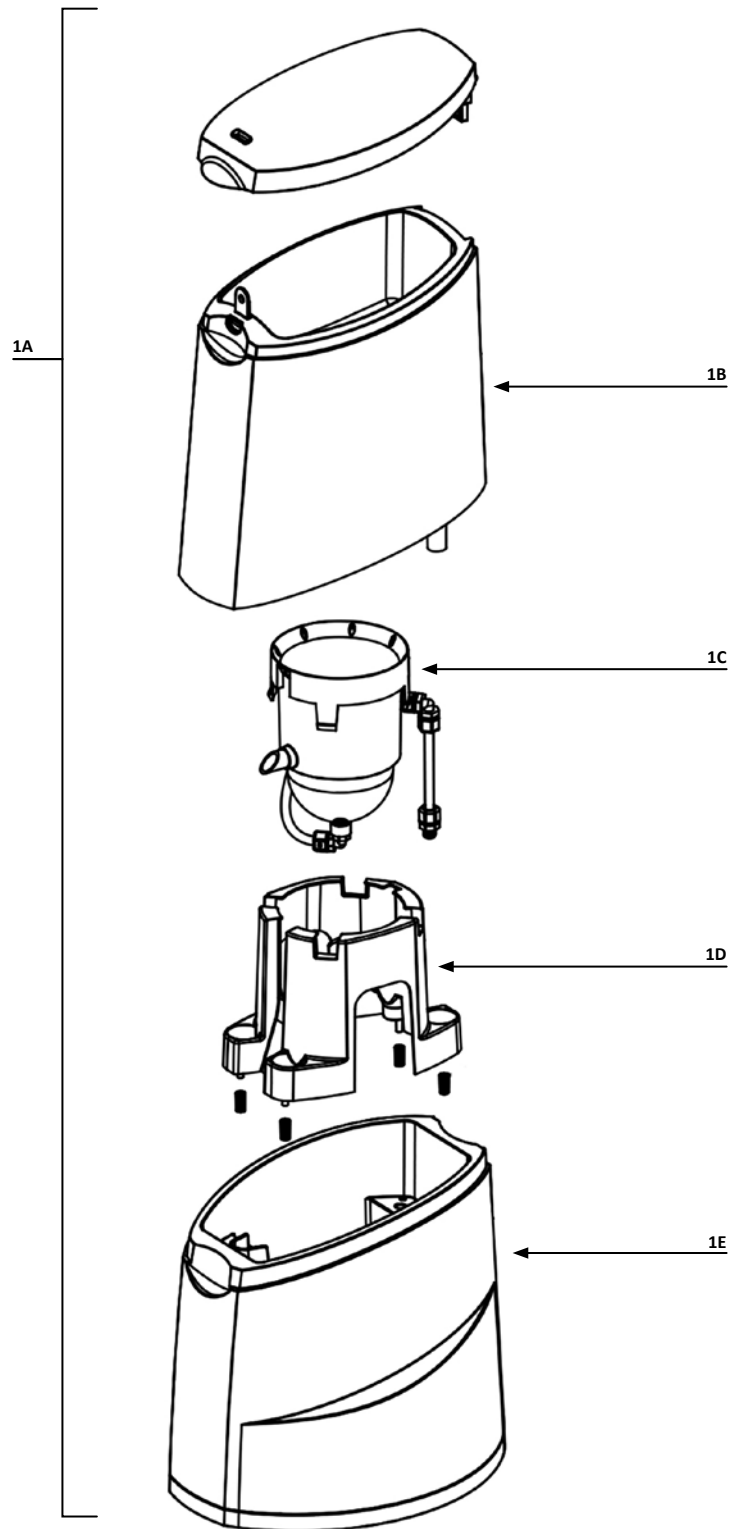
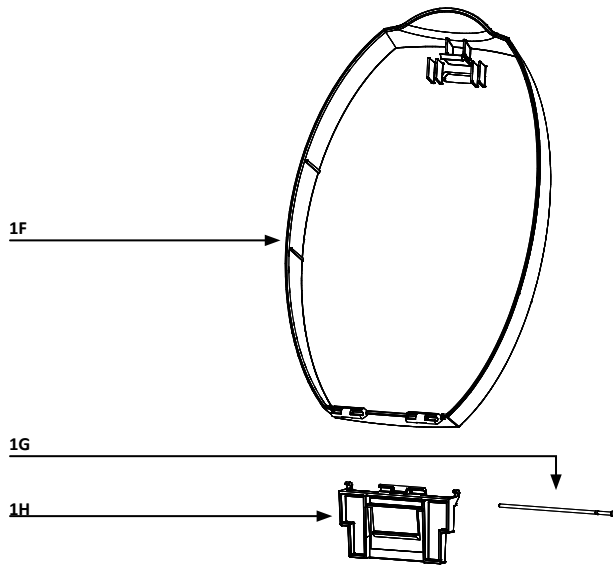

Part	Description	Part No.
2	HOPPER INTERIOR COMPONENTS	
2A	Emergency Shut Off Mounting Plate	205451
2B	Rubber Gasket for Emergency Shut Off Valve	205540
2C	Emergency Shut Off Valve with Arm only	205450
2D	Emergency Shut Off Float Plate	590045
2E	Emergency Shut Off Float Plate PVC Nut	205453
2F	Emergency Shut Off Overflow Float	205454
2G	Discharge Valve Gasket (not shown)	938033
2H	Discharge Valve Lock Nut	938034
2I	Emergency Shut Off Mounting PVC Screws, 1/4"-20 x 2-1/4" (pkg of 4) (not shown)	205452
2J	Discharge Valve Float	206082
2K	Discharge Valve Arm with Seal Pad	206079
2L	Discharge Valve Body	206080
2M	DV Seal Pad Only	251388
2N	DV Arm Only	205960

Figure 5. Feeder Inlet and Discharge Components View

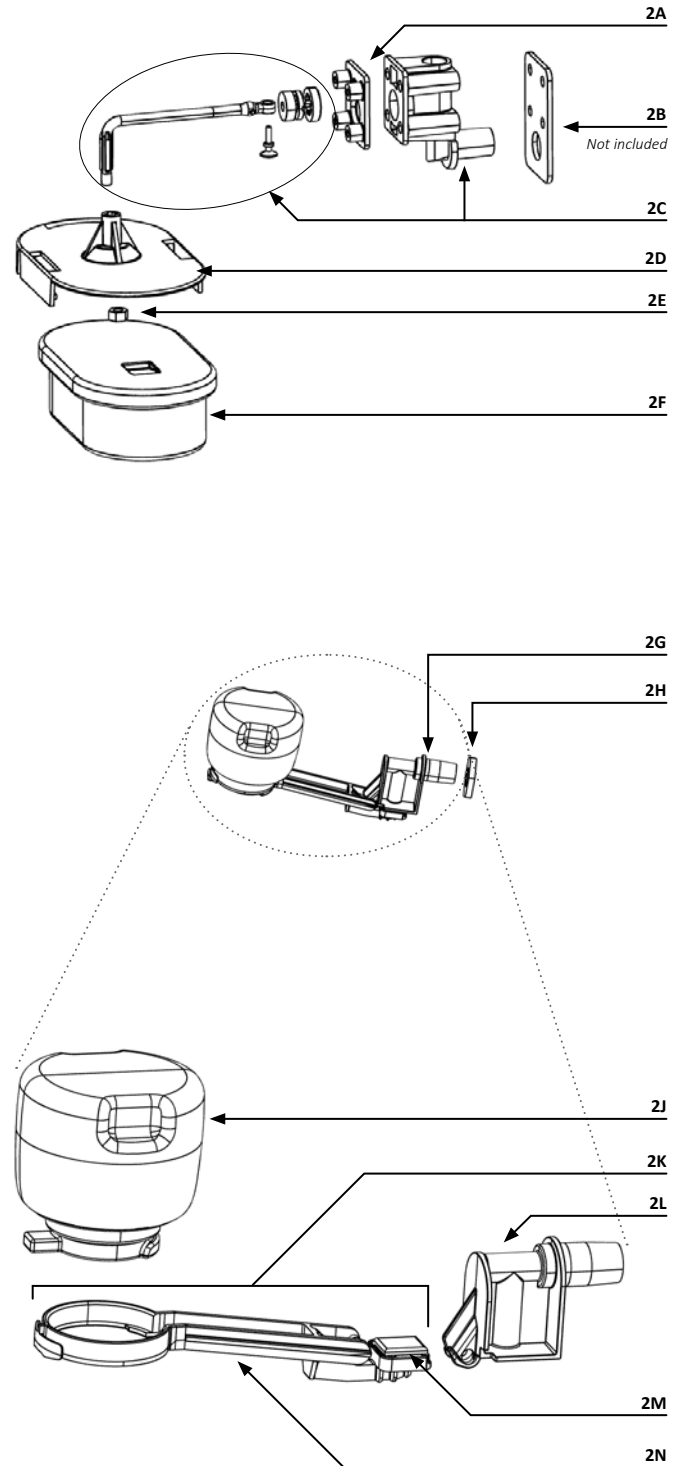

Part	Description	Part No.
3	BASE INTERIOR COMPONENTS AND ESV	
3A	HCE 30 Grid	251588
3B	HCE Diffuser	868047
3C	HCE 30 Nozzle	251584
3D	Parker Fitting F8FE8	205938
3E	Tubing Reducing Union, P8CU6	251587
3F	3/8" PE Tubing 2ft	205486
3G	Parker Fitting, P6MC6	251592

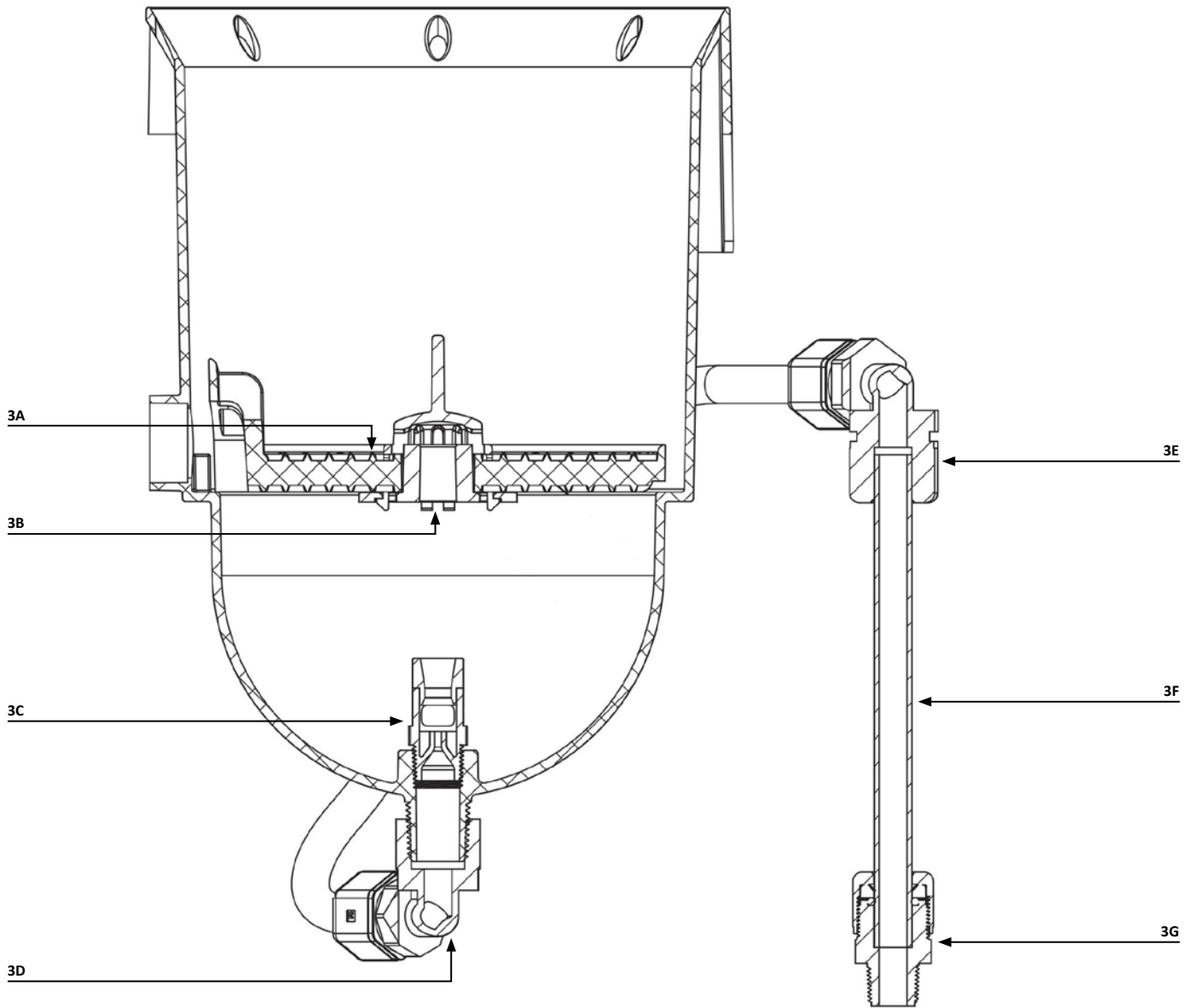

Figure 6. Base Interior Components View

Part	Description	Part No.
4	EXTERIOR COMPONENTS	
4A	45° PVC ½" FNPT Threaded Elbow	205963
4B	½" threaded PVC Nipple, closed	205480
4C	½" FNPT PVC True Union Check Valve	205959
4D	Connector Male ½" P8MC8	71890
4E	20' ½" O.D. PE Tubing	205490
4F	½" FNPT X ½" FNPT PVC Ball Valve	205605
4G	Tube Connector (P8MC4)	205483
4H	Flow Indicator 0-2 gpm	205634
4I	ORP/Below Grade Installation Kit for Small Feeder	205562

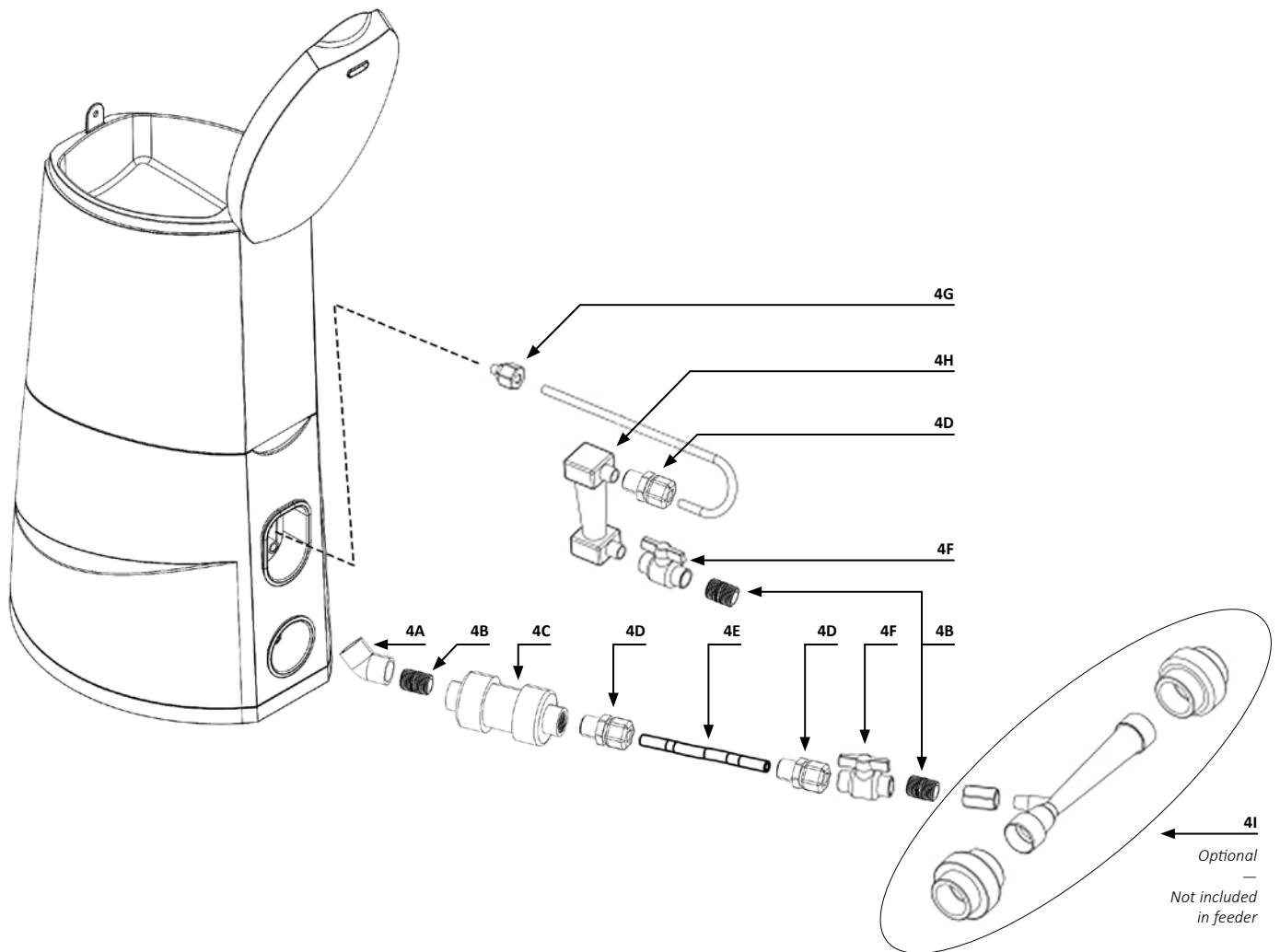

Figure 7. Exterior Components View

Limited Warranty

The Pulsar® Precision 30 Feeder is warranted against any manufacturing defects in material or workmanship for a period of 12 months after installation or 18 months after shipping from Solenis, whichever is earlier. This warranty applies only to the original end-user.

To register your feeder please visit www.pulsarsystems.net

Service

For warranty service, contact the authorized Pulsar® Dealer in your area. Any defective part(s) covered by this warranty will be repaired or replaced, at the discretion of Solenis. Replacement may be with either new or reconditioned parts.

Exclusions

This warranty does not cover damage or failure due to accidents, fire, flood, or other acts of God. Nor does it cover damage or failure due to abuse, misuse, abnormal or improper use, neglect, improper maintenance, alterations, or modifications by anyone other than Solenis (unless specifically approved in writing by Solenis), repairs by anyone other than an authorized Dealer, or ordinary wear and tear.

Use of any other chemicals other than the Pulsar® Plus Briquettes designed for use with this chlorinator shall void this warranty.

Any transportation to and from an authorized Pulsar® Dealer is your responsibility.

Neither Solenis nor its Dealers are responsible or liable for indirect, special, or consequential damages arising out of or in connection with the use or performance of the product or other damages with respect to loss of property, loss of revenues or profit by the owner. EXCEPT AS PROVIDED ABOVE, Solenis MAKES NO WARRANTIES. ANY IMPLIED WARRANTY OF MERCHANTABILITY OR FITNESS FOR A PARTICULAR PURPOSE IS SPECIFICALLY EXCLUDED.

Note: No modifications may be made to the feeder without prior written approval from Solenis. Unauthorized modifications void any warranty. This Pulsar® Precision 30 Feeder is subject to one or more patents owned by Solenis, and all rights in any modifications or improvements, including but not limited to any patents, copyrights, trademarks or trade secrets, belong exclusively to Solenis.

For information, contact Innovative Water Care at (800) 478-5727.

This page intentionally left blank.

Pulsar® Systems

1400 Bluegrass Lakes Parkway

Alpharetta, GA 30004

www.pulsarsystems.net

1-800-4-PULSAR

Pulsar® and Pulsar® logos are trademarks of Innovative Water Care, LLC or its affiliates.

©2022 Innovative Water Care, LLC

